

ALL DIMENSIONS IN MILLIMETRES AND/OR METRES, DRAWING NOT TO SCALE

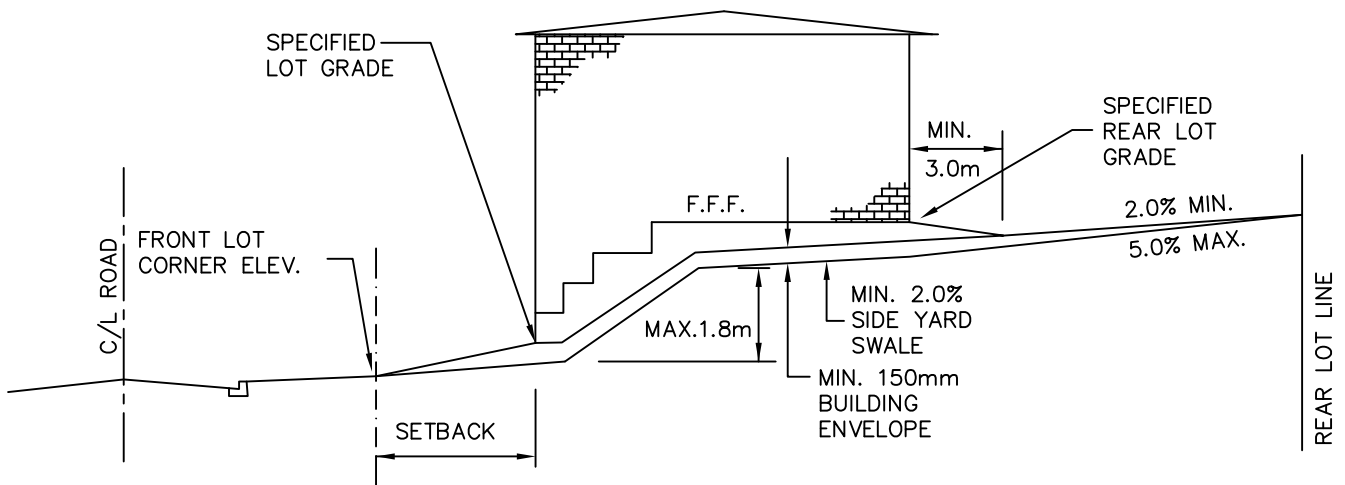

NOTES:

1. MAX. REAR YARD GRADE DIFFERENTIAL NOT TO EXCEED 15% INCLUDING RETAINING WALLS AND 3:1 SLOPES, MEASURED FROM REAR OF HOUSE TO REAR LOT LINE.
2. REAR YARDS TO HAVE MIN. USABLE (CONTINUOUS SLOPE NOT EXCEEDING 5.0%) DEPTH OF 6.0m.
3. DRIVEWAYS SHALL NOT BE USED AS AN OUTLET FOR ANY SWALES.
4. SPECIFIED LOT GRADE SHALL BE CALCULATED AS FOLLOWS: A SWALE GRADIENT OF 2.0% MIN. TO 5.0% MAX. FROM THE FRONT HIGH LOT CORNER AT THE STREETLINE TO THE SWALE HIGH POINT ELEVATION 'A'. THE SPECIFIED LOT ELEVATION SHALL BE SET A MINIMUM OF 0.150m HIGHER THAN SWALE ELEVATION 'A'.
5. MAX. DEPTH FOR REAR AND SIDEYARD SWALES IS 500mm.
6. MAX. DISTANCE FROM C/L SWALE TO AN ADJACENT PROPERTY LINE IS 1.50m.
7. FRONT SPLIT DESIGN TO BE USED ONLY WITH THE PERMISSION OF THE TOWN.

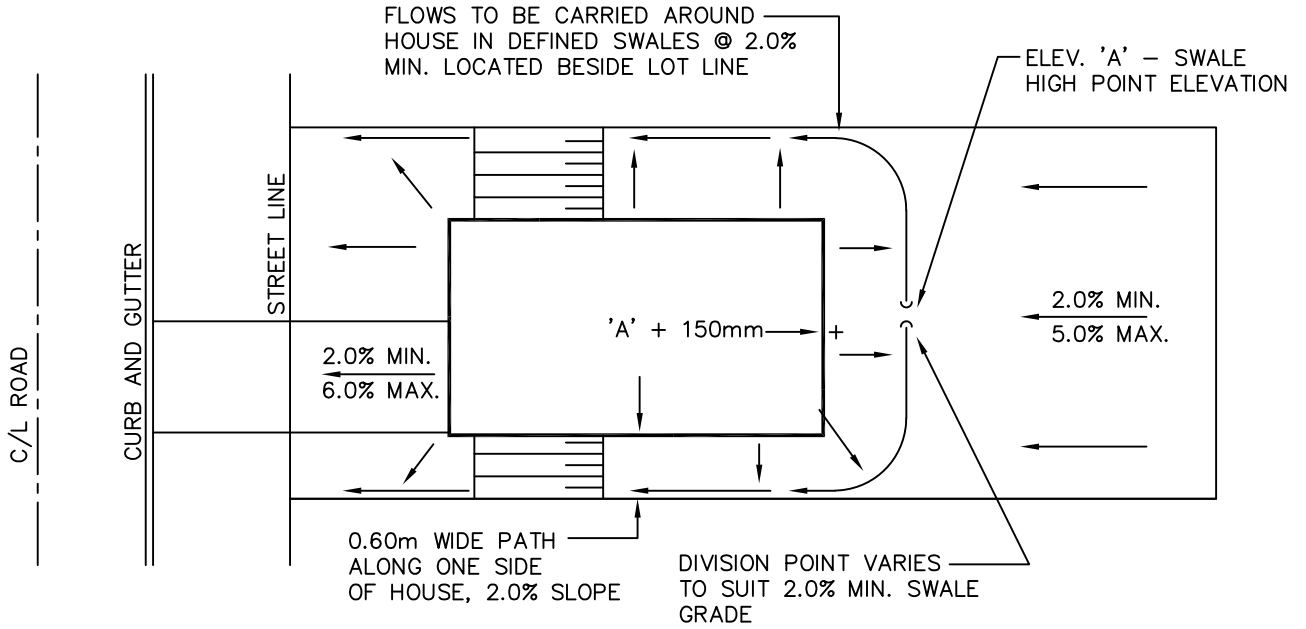
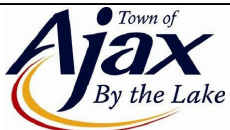

ENGINEERING SECTION

**FRONT SPLIT TYPE HOUSE
FRONT LOT DRAINAGE**

DWG. No.

AS-404

DATE

JANUARY 2011

REVISION No.